

Electric pump

EL150A/B

PUMP SPECIFICATIONS	Mod. A	Mod. B
Capacity [m ³ /h]	720	900
Head [m]	22	18
Impeller diameter [mm]/type	760/2 blades closed	
Flanged bore size [DN.../PN...]	DN250/PN10	DN300/PN10
Cross section diameter [mm]	120	
Weight (without cable) [kg]	4520	4570

ELECTRIC MOTOR	
Power [kW-HP]	110-150
Voltage [V]/Current [A]	400/240
Phases/Poles/Frequency [Hz]	3/10/50
Speed [RPM]	600
Insulationclass	H
Powercable 20m (IEC 60245- 4)	H07RN-F 4G95

MATERIALS	
Casing	Spheroidal cast iron EN-GJS-500-7 (EN 1563)
Motor housing	Cast iron EN-GJL-250 (EN 1561)
Wear parts	High chrome EN-GJN-HV600 (XCr18) (EN 12513)
Main shaft	High tensile steel 39NiCrMo3 (AISI 9840)

SEALS / LUBRICANT	
Motor side seals	3 lip seals (2 BUNA + 1 PTFE)
Impeller side seals	5 lip seals (3 BUNA + 2 PTFE)
Oil type	ISO 320

DIMENSIONS [mm]							
H	W	D	F	H1	A	B	C
2650	1595	1360	1015	1800	650	750	600

PERFORMANCE CURVES

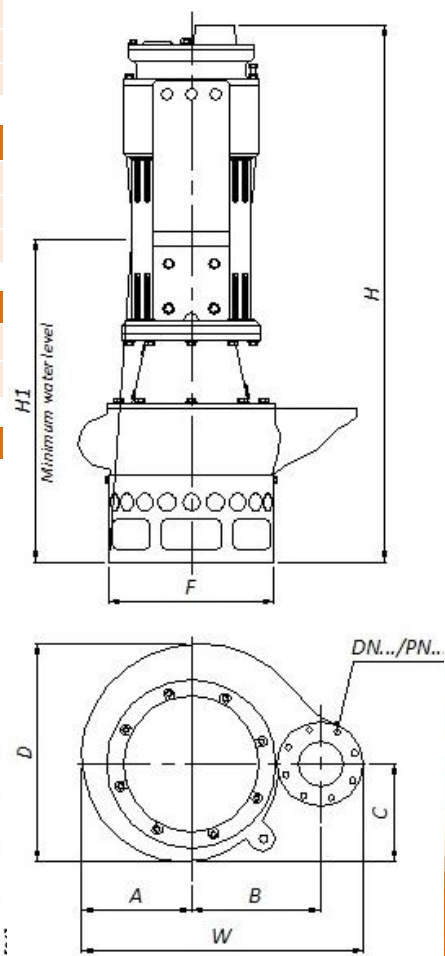
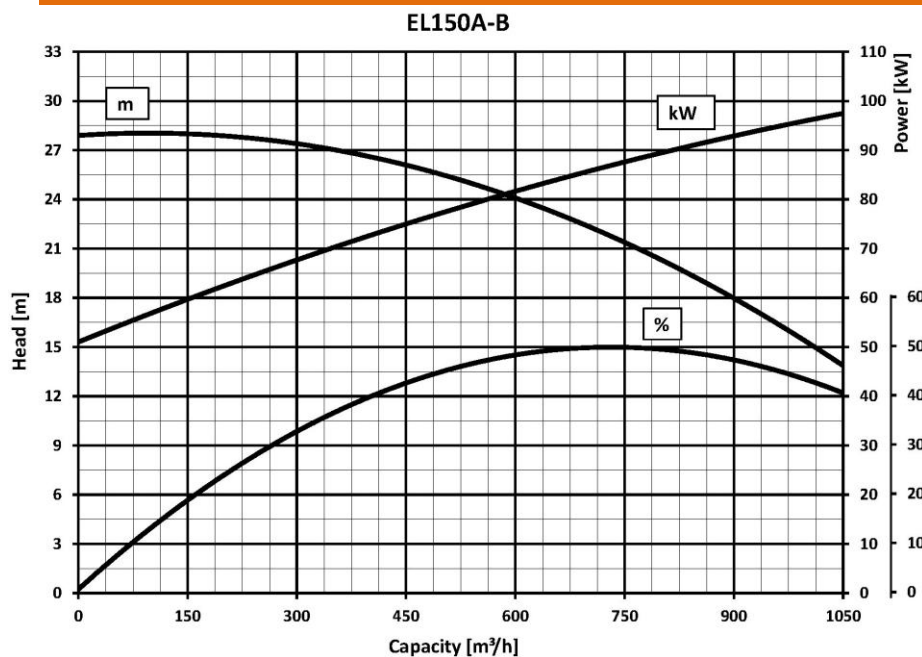

We reserve the right to make changes without notice

EL150A-B

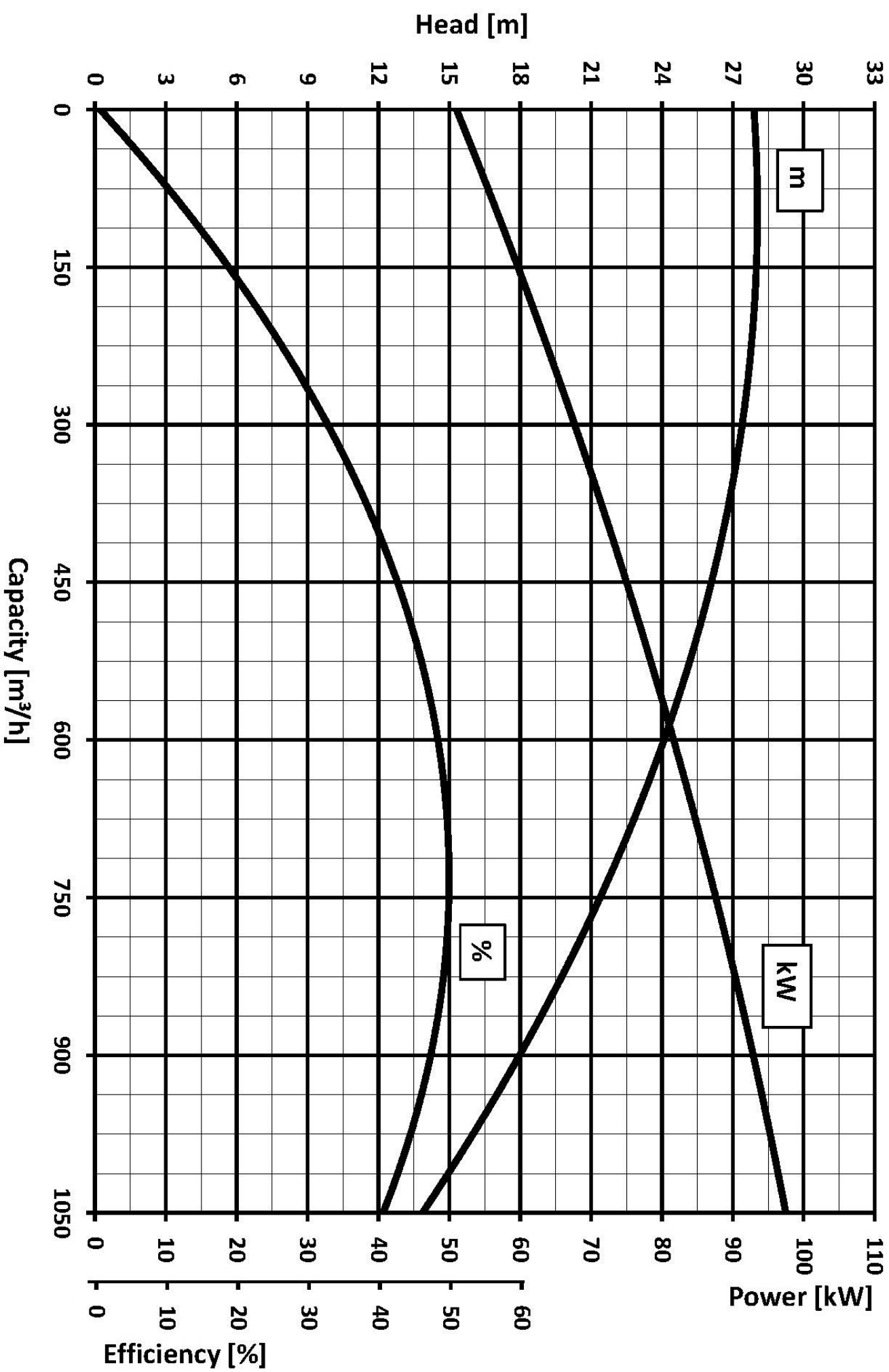

We reserve the right to make changes without notice