

Electric pump

EL604SHHA/B

| PUMP SPECIFICATIONS | Mod. A | Mod. B |
|---------------------------------|---------------------|------------|
| Capacity [m ³ /h] | 100 | 200 |
| Head [m] | 49 | 35 |
| Impeller diameter [mm]/type | 435/3 blades closed | |
| Flanged bore size [DN.../PN...] | DN100/PN10 | DN150/PN10 |
| Cross section diameter [mm] | 35 | |
| Weight (without cable) [kg] | 1100 | 1130 |

| ELECTRIC MOTOR | |
|--------------------------------|--------------|
| Power [kW-HP] | 90-120 |
| Voltage [V]/Current [A] | 400/158 |
| Phases/Poles/Frequency [Hz] | 3/4/50 |
| Speed [RPM] | 1450 |
| Insulation class | H |
| Power cable 20m (IEC 60245- 4) | H07RN-F 4G35 |

| MATERIALS | |
|---------------|---|
| Casing | Spheroidal cast iron EN-GJS-800-2 (EN 1563) |
| Motor housing | Cast iron EN-GJL-250 (EN 1561) |
| Wear parts | High chrome EN-GJN-HV600 (XCr18) (EN 12513) |
| Main shaft | High tensile steel 39NiCrMo3 (AISI 9840) |

| SEALS / LUBRICANT | |
|---------------------|--|
| Motor side seals | 1 mechanical seal (silicon carbide in oil bath) |
| Impeller side seals | 1 mechanical seal (silicon carbide in oil bath) + 1 lip seal (BUNA) + 1 V-RING (TPU) |
| Oil type | ISO 320 |

| DIMENSIONS [mm] | | | | | | | |
|-----------------|-----|-----|-----|------|-----|-----|-----|
| H | W | D | F | H1 | A | B | C |
| 1450 | 902 | 774 | 600 | 1000 | 374 | 418 | 363 |

PERFORMANCE CURVES

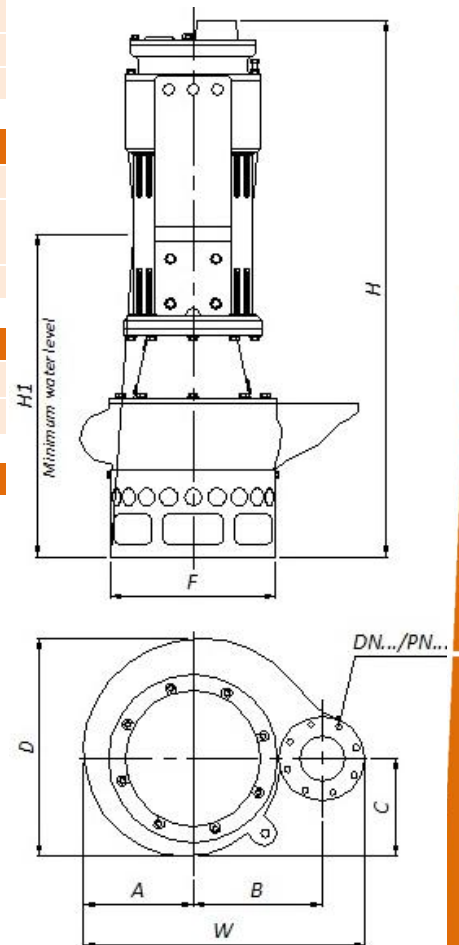
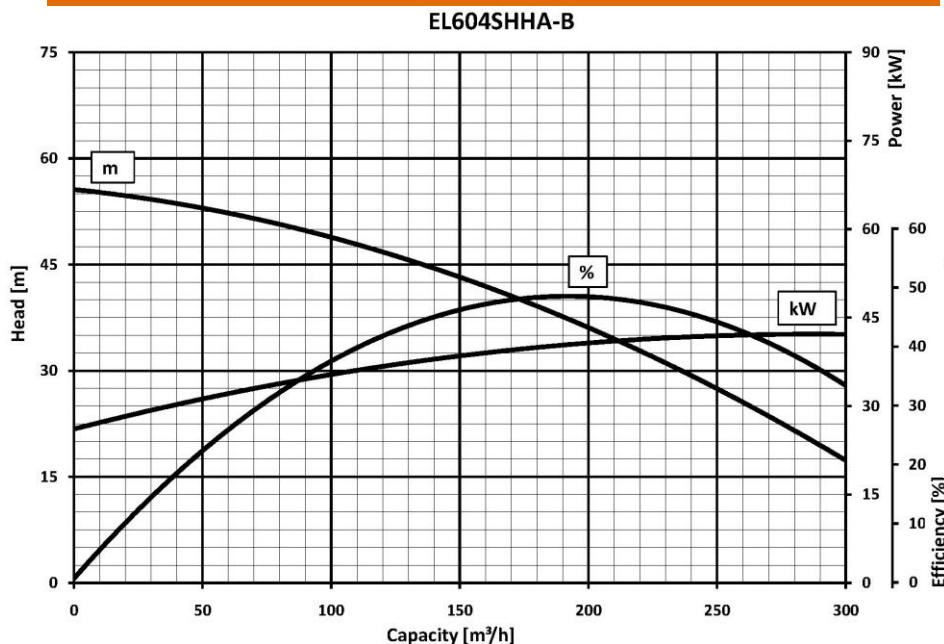

EL604SHHA-B

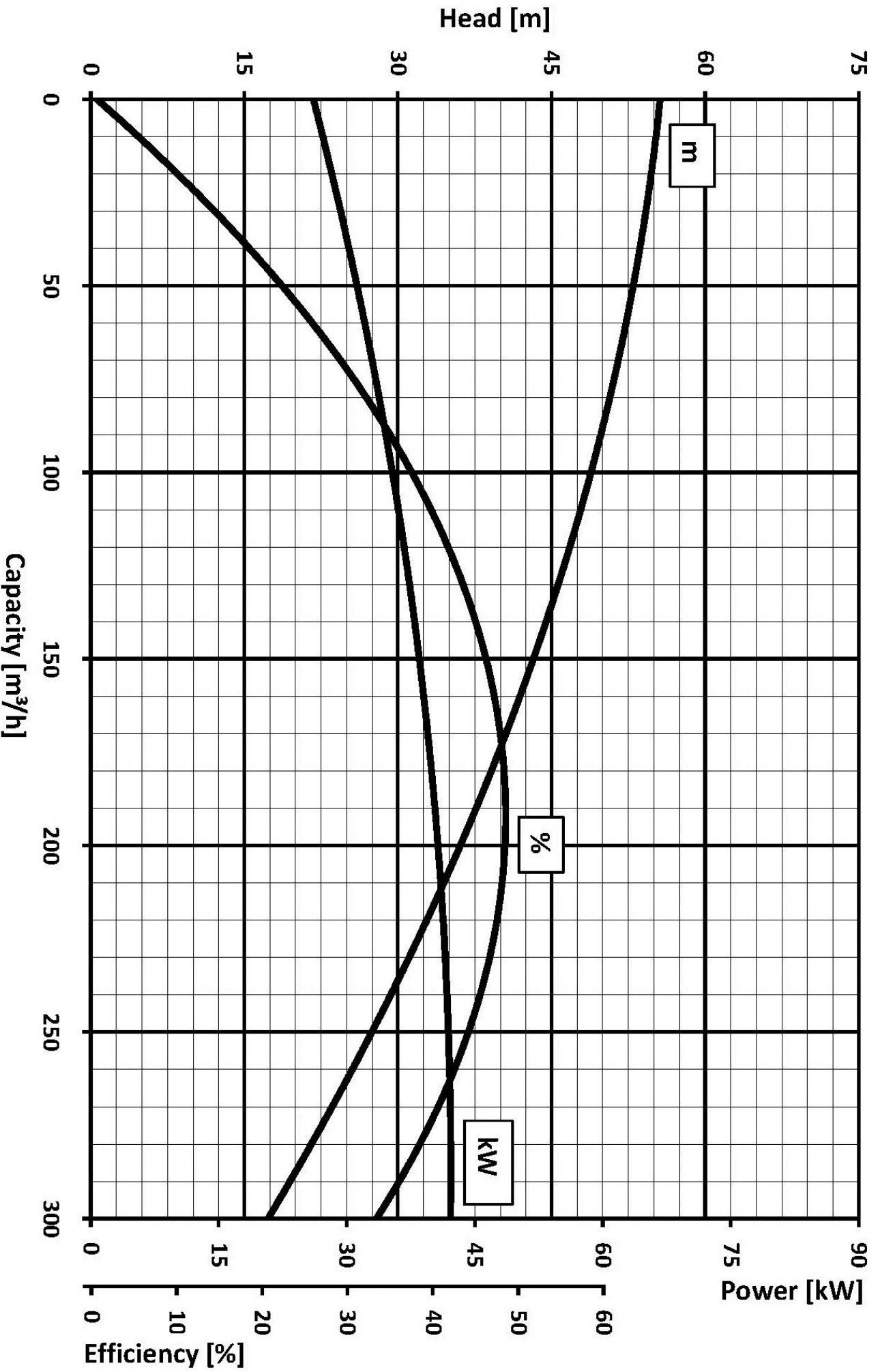

We reserve the right to make changes without notice